



The LF24-SR is a 24 V modulating damper actuator intended for operation of air dampers of up to approximately 0.8 m² (8.6 ft²) cross sectional area that perform safety functions, e.g. frost and smoke protection, hygiene, etc.

Control is effected by means of an electronic controller with a signal of 0–10 V DC and a continuous position feedback of 2–10 V DC.

Either direction of rotation can be selected.

The spring return operates as a safety function if the power supply fails or is interrupted. The spring pretensioning can be manually adjusted.

TECHNICAL DATA

| | |
|---------------------------|--------------------------------------------------------------------------------------------------------|
| Part number..... | 877-0003-000 |
| Power supply | 24 V AC ±20%, 50–60 Hz, 24 V DC -10%, +20% |
| Power consumption: | |
| Opening | 2.5 W |
| Open | 1 W |
| For wire sizing | 5 VA (I _{max} =5.8 A for 5 ms) |
| Connection cable | 1.0 m (3.3 ft), 4x0.75 mm ² (AWG18) |
| Control signal X..... | 0–10 V DC |
| Input resistance | 100 kΩ |
| Operating range | 2–10 V DC (for 0–100% <input checked="" type="checkbox"/>) |
| Measuring voltage Y | 2–10 V DC (max. 0.7 mA) for 0–100% <input checked="" type="checkbox"/>) |
| Angle of rotation | max. 95° (adjustable 37–100% <input checked="" type="checkbox"/> with additional limit stop ZDB-LF) |
| Torque: | |
| Actuator | min. 4 Nm (3 ft-lbf) (at rated voltage) |
| Spring return | min. 4 Nm (3 ft-lbf) |
| Running time: | |
| Actuator | 150 s |
| Spring return | approx. 20 s (at -20 to +50 °C (-4 to +122°F)), max. 60 s (at -30 °C (-22°F)) |
| Direction of rotation: | |
| Actuator | selected with switch L/R |
| Spring | selected by L/R mounting |
| Position indication | mechanical |
| Standard conformity: | |
| EMC, emission | EN 50081-1 |
| EMC, immunity | EN 50082-1 |
| Protection class | III (safety extra-low voltage) |
| Enclosure rating | IP 54 |

mm (in.):

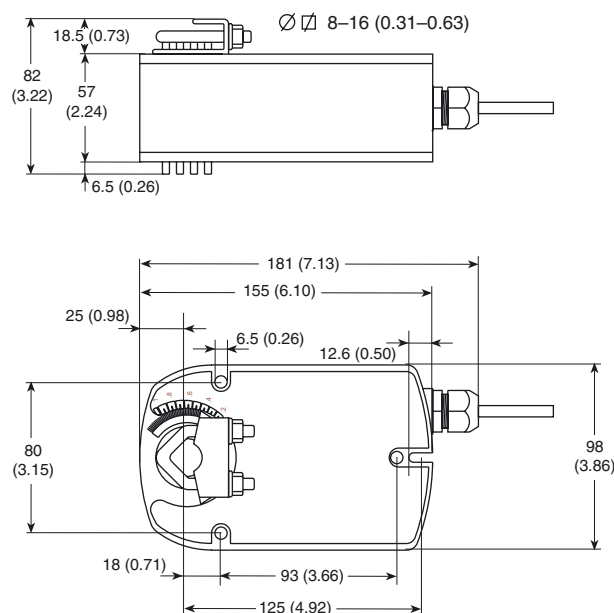

| | |
|------------------------|--------------------------------|
| Ambient humidity | EN 60335-1 |
| Ambient temperature: | |
| Operation | -30 to +50 °C (-22 to +122 °F) |
| Storage | -40 to +80 °C (-40 to +176 °F) |
| Sound power level: | |
| Actuator | max. 30 dB (A) |
| Spring return | approx. 62 dB (A) |
| Service life | min. 60 000 operations |
| Maintenance | maintenance-free |
| Weight | 1.4 kg (3.1 lb.) |

WIRING DIAGRAM



Connect via safety isolating transformer.

Measuring voltage Y for position indication or as master-slave control signal.

Parallel connection of several actuators is possible. Power consumption must be observed.

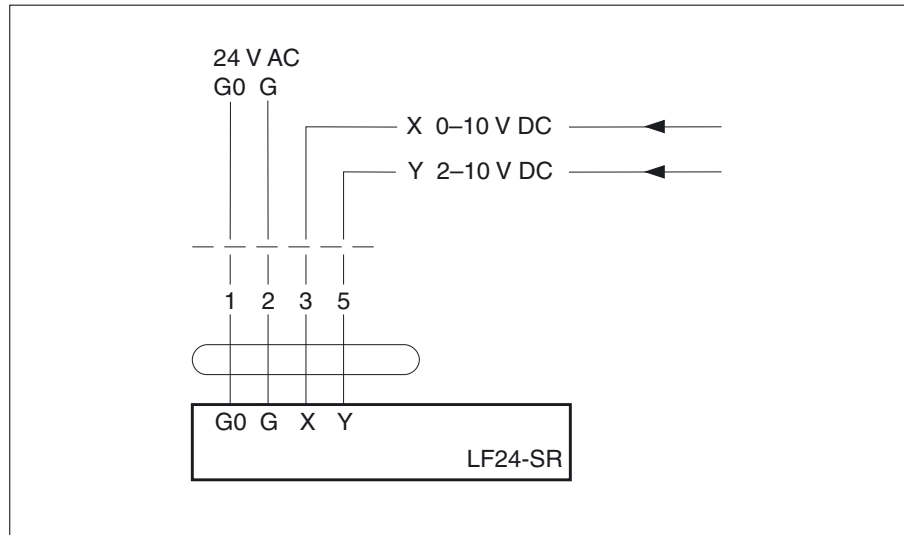

MODE OF OPERATION

The actuator is fitted with a universal spindle clamp for quick and easy mounting directly onto the damper spindle. The actuator is also supplied with an anti-rotation strap for fixing it in position. The direction of rotation can be selected with the L/R switch. The direction of rotation for the spring is selected by mounting left or right.

The actuator has a mechanical angle of rotation limiting, adjustable with an additional limit stop.

The LF24-SR is controlled by a modulating 0–10 V DC signal. The actuator runs to the position specified by the control signal while tensioning the return spring at the same time.

If the power supply is interrupted, the energy stored in the spring moves the damper back to its safe position $\leq 0^\circ$.

The actuator is supplied from factory with 5° of pretensioning. The pretensioning can be unlocked manually by means of a crank or electrically by connecting the power supply. The actuator will then be moved back to its safe position $\leq 0^\circ$.

The actuator is overload-proof and needs no limit switches. It stops automatically at the end stops.

NOTE

When calculating the torque required to operate dampers, it is essential to take into account all the data supplied by the damper manufacturer concerning cross sectional area, design, mounting and air flow conditions.

ACCESSORIES

Please refer to data sheet G-30-90 "Accessories Damper Actuators" (part. no. 0-003-2251).

